

LEDs: A closer look

Presented by
Eric Strandberg, LC

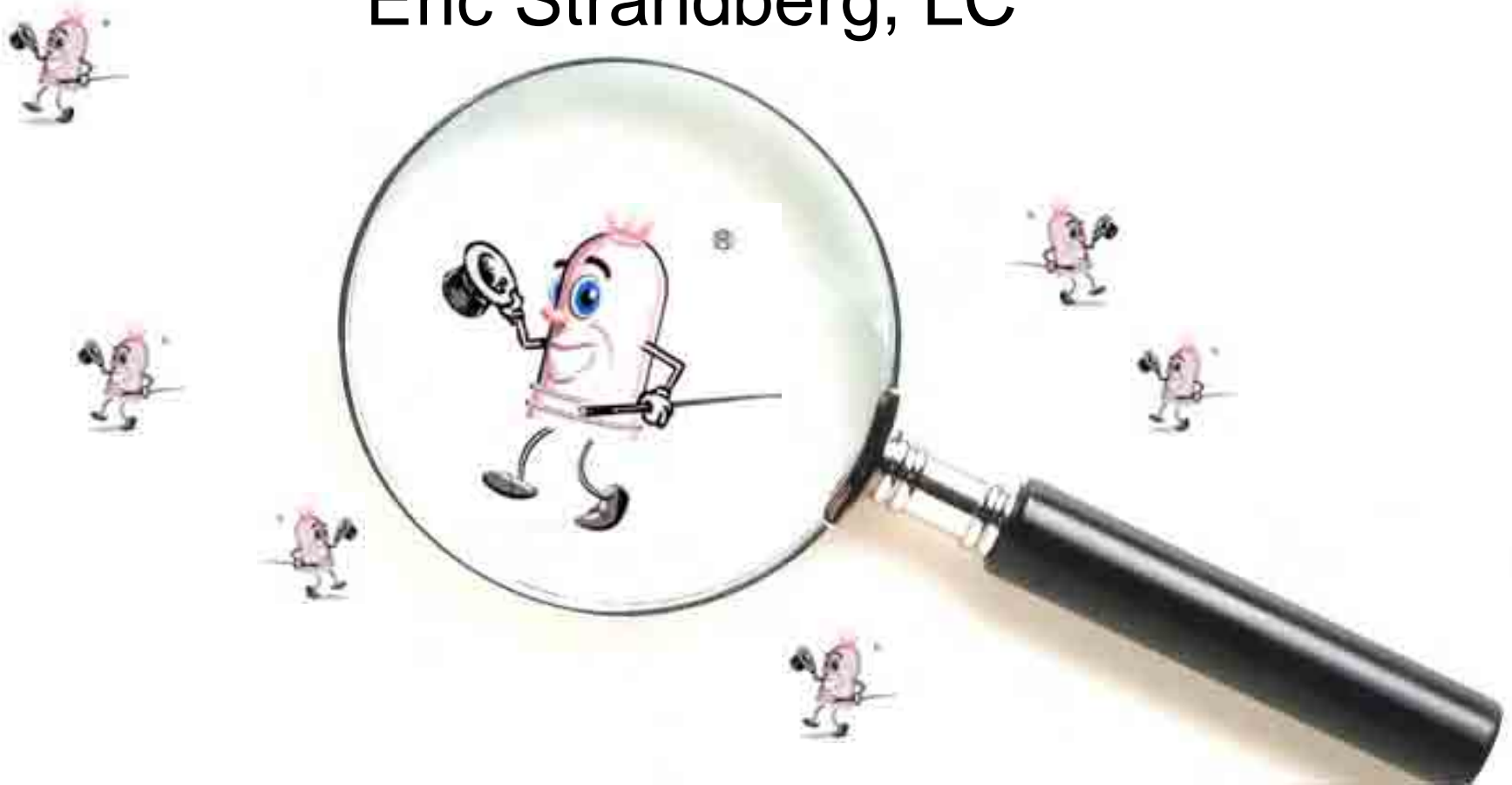

Agenda – LEDs:

- What are they?
- What do they do?
- Who uses them?
- Where can I use them?
 - Applications
- Why should I use them?
- Who can help me find out more?

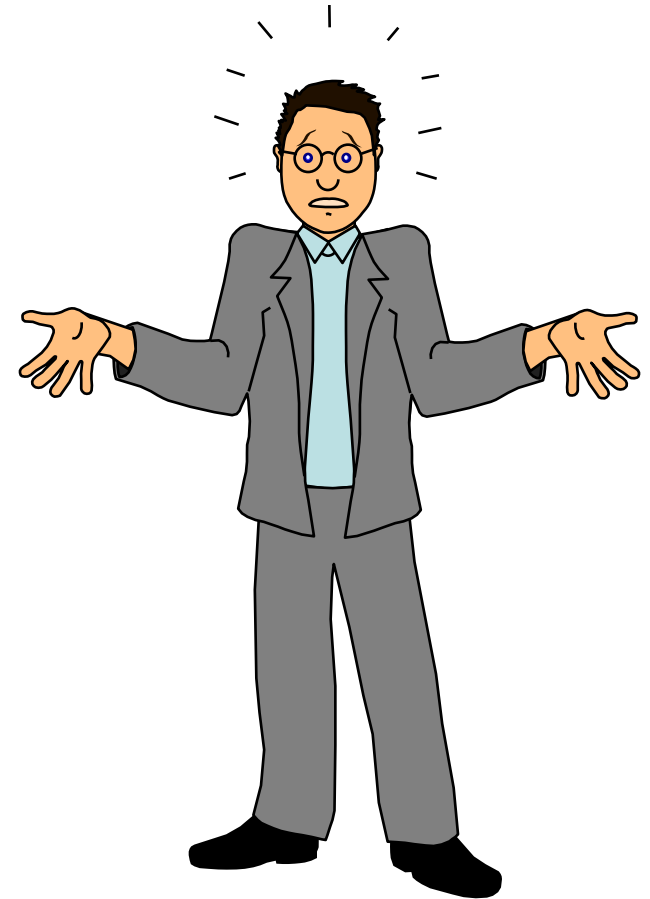

Why the buzz



Everyone seem to have their hair on fire to use LEDs

- **“Why LED's?:**
- LED's have begun to light the future with their capabilities of reducing power consumption by 80% over conventional lighting.”
- “Their "light" span is a minimum of 10 years for commercial usage, and a minimum of 25 years for residential applications.”
- “Besides eliminating the environmental hazards of mercury in fluorescents,”
- “LED's quietly illuminate with the closest look of natural daylight”
- GE- 1w led = 35 lumens,
- 7w led = 200 lumens (28 l/w)
 - 60w Inc = 14 l/w
 - 26w CFL = 31 l/w
 - 32w T8 = 90+ l/w
 - 150w CMH = 75 l/w
- LED life usually = 50,000 hrs
 - Incandescent = 1,000 hrs
 - Halogen = 3,500 hrs
 - CFL = 10,000 hrs
 - 4' T8 fluorescent = 30,000 to 46,000 hrs
 - Induction = 60,000 to 100,000 hrs
- LEDs have many exotic chemicals used in them and in production.

- “LED's quietly illuminate with the closest look of natural daylight”

Led light compared to daylight

VIGC study: 2 different light sources used in spectrophotometers

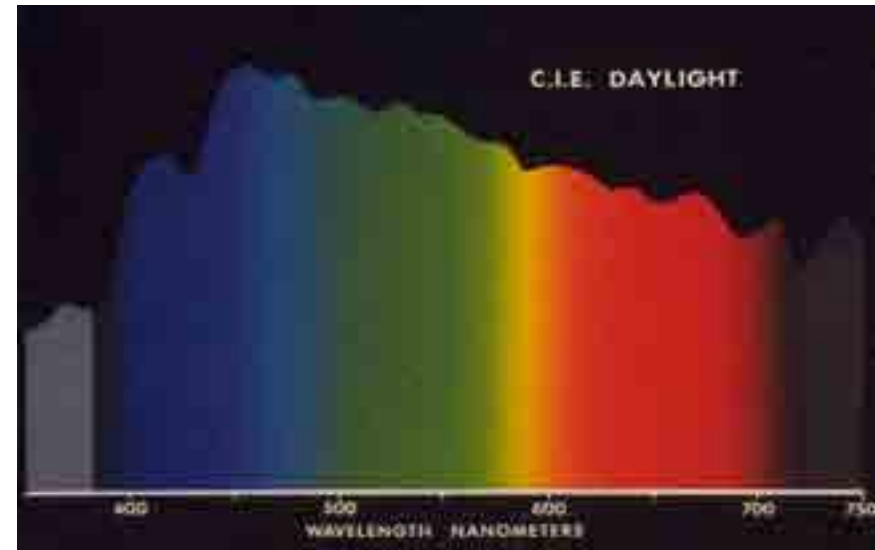
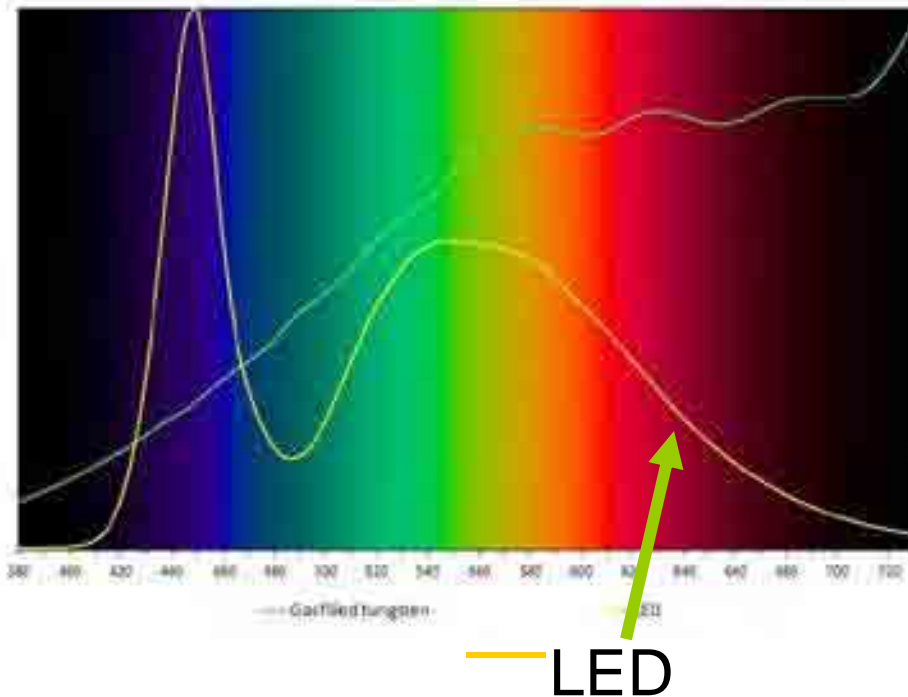

Daylight

What is an LED?

- Light Emitting Diode
 - Color
 - White



How do LEDs work?

- Like a normal diode, the LED consists of a chip of semiconducting material impregnated, or doped, with impurities to create a **p-n junction**.

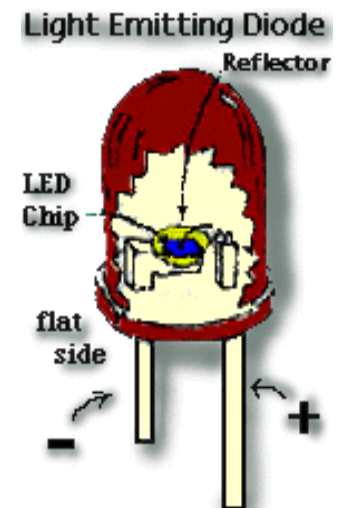
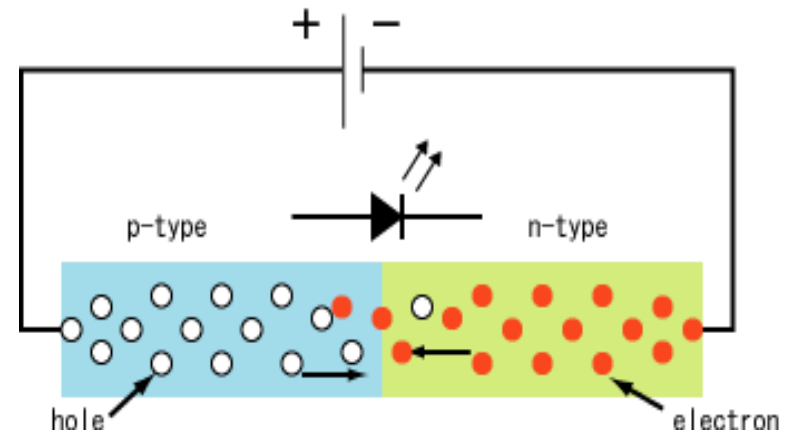

LED basic components

- LED chips are made of silicone (like computer chips), and then mounted in a “package” that has electrical leads and sometimes heat sinking.

Chips



Package

Heat management



PHILIPS LUMILEDS™
LIGHT FROM SILICON VALLEY

- Getting heat away from the junction is critical to LED performance;
 - *Life*
 - *Light output*
- The package is then attached to a heat sink, that then becomes a part of; either a “lamp” or a luminaire

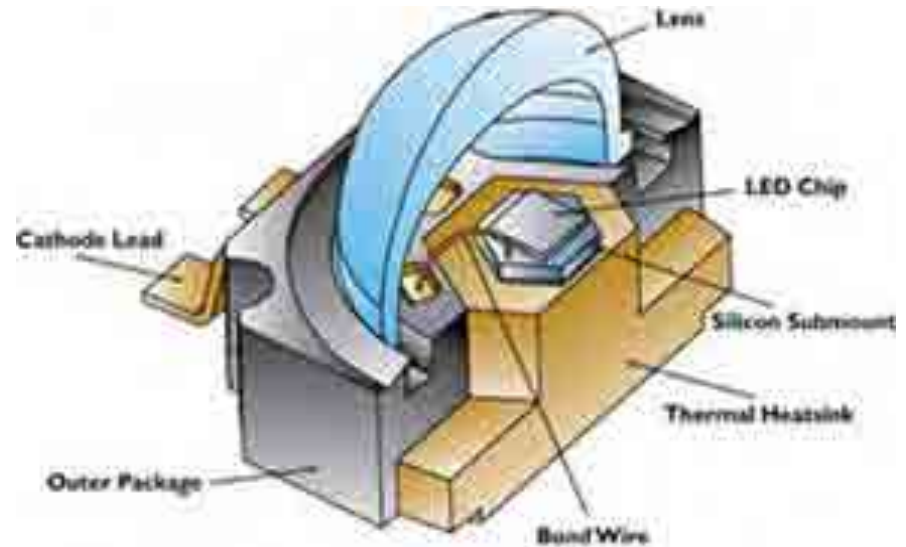

Luminaire

Lamp





Leds are small



- Which can make for small sized fixtures



Heat management

- If the fixture/ lamp is too small, and/or the power is too high, then over heating can occur.
- Lumens/watt can be reduced at a # of points:
 - Chip has X lumens/watt
 - Package has less
 - Powersupply = less still
 - Luminaire = still lower l/w than the original chip.

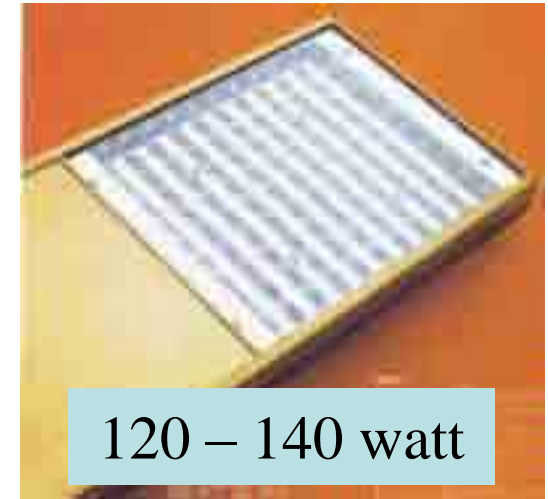

Most LEDs are directional

- The chip is located in a little reflective cup that sends the light in a direction.

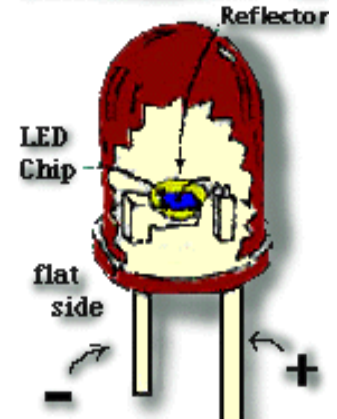

LED light distribution

- Which makes them good for applications that require a spot light.



LED light distribution

- But not so good for applications better suited to omnidirectional lamps.

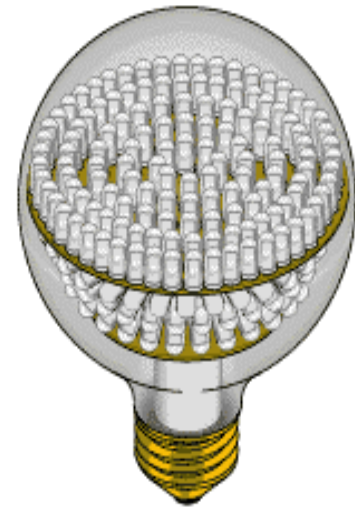

LED light distribution

- Some LEDs have diffusion lenses to spread out the light, or don't have the reflective cup.

Light Cones Emitted by Clear and Diffuse LED Lenses

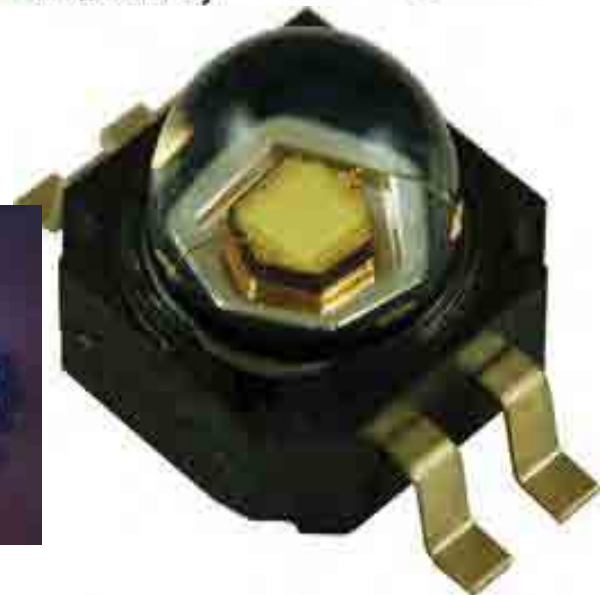
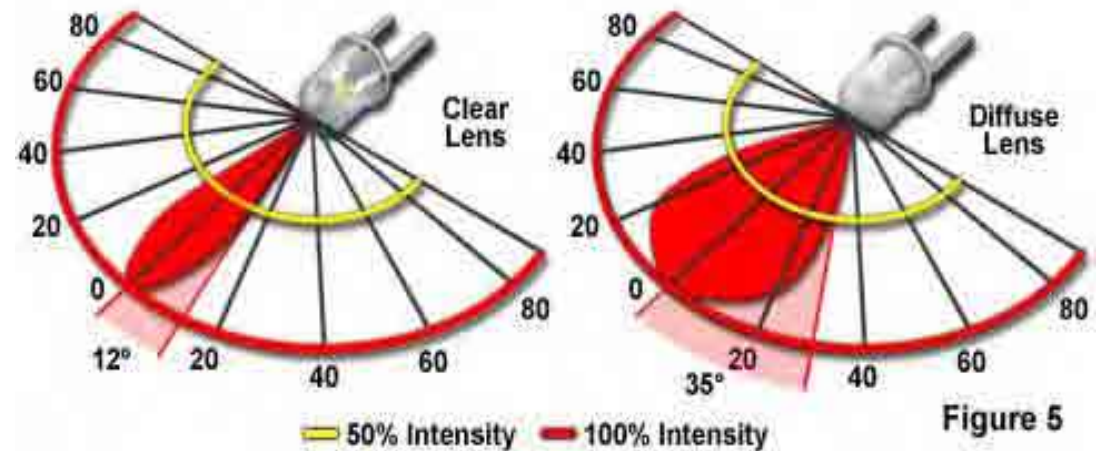

“White” LEDs

- White light LEDs are generally made by taking a blue LED and “doping” it with yellow phosphors

Phosphor-Based White LED Emission Spectrum

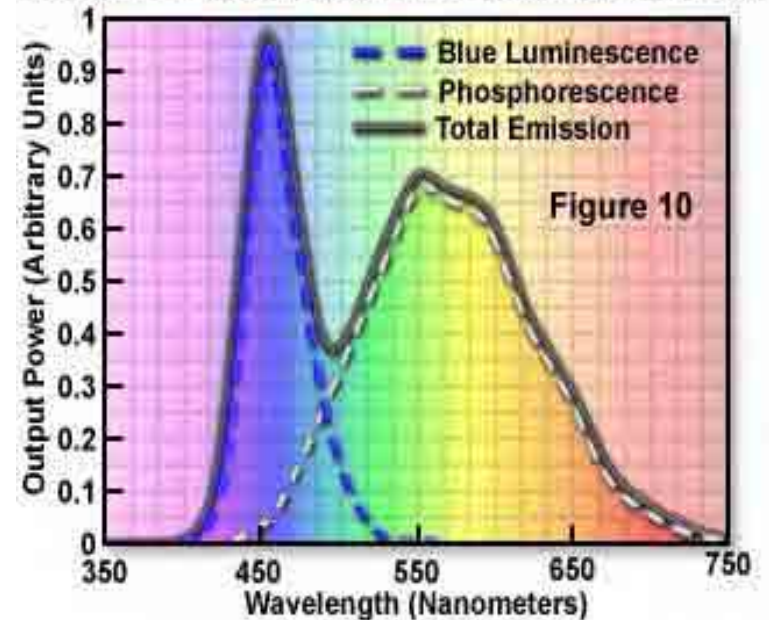

LEDs & color

- Many “white” LEDs are a pale blue color, 6500 to 5000 Kelvin's.



6,000 K

LEDs & color

- They are sometimes available in a “warm” color temperature, but this is often fairly cool also. (3500 to 4500 K)
- Its just warmer than “cool”



4,000 K



6,000 K

LEDs & color

- If what you are expecting is like incandescent, (2700 to 3000 Kelvins), then you may be somewhat disappointed. They don't usually come that warm.



3,000 K



4,000 K



6,000 K

LEDs and color



The cool color looks like metal halide, which can make them a good fit for exterior applications.

Note the yellow HPS on right and the bluer LED on the left.

Applications

- Freezer case
- Undercabinet / Task
- Recessed
- Outdoor

- Left: Fluorescent-lighted freezer with an average illuminance of 2871 lx. Right: LED-lighted freezer with an average illuminance of 2470 lx.
- The LED freezer provided an even illuminance uniformity across the freezer case. This led to greater preference for the LED freezer, even at a lower average illuminance level.
- White LEDs of different distributions were used to effectively and uniformly illuminate the freezer interior.



Completed Research:

Lighting Supermarket Freezers with LEDs

- The potential exists now for LED lighting in commercial refrigeration to match or even surpass fluorescent lighting in terms of shopper satisfaction.
- Shoppers in this study showed greater preference for the LED freezer, most likely because of its better illuminance uniformity and higher CCT.
- At a dimmer light level, LEDs are now at a “threshold” efficacy where they fall slightly below the energy consumption of fluorescent lighting without sacrificing shopper satisfaction.
- Using 2006 LED light sources with a luminous efficacy of 45 lm/W, a dimmed LED lighting system would show a savings of 14 W over fluorescent lighting in a four-door freezer.

ASSIST recommends...

- Linear task lights



Each cabinet features an LED fixture. The fixture on the right provides poor uniformity and distribution, creating a central pool of light on the counter, poor lighting on the backsplash, and dark areas on the counter.

- Linear task lights



14 watt T5 linear fixture
Average illuminance: 405 lux
Minimum illuminance: 128 lux
Meets recommendation for critical tasks? Yes
Uniformity on counter: 3:1



16 watt T4 linear fixture
Average illuminance: 408 lux
Minimum illuminance: 140 lux
Meets recommendation for critical tasks? Yes
Uniformity on counter: 3:1



18 in. xenon linear fixture
Average illuminance: 204 lux
Minimum illuminance: 72 lux
Meets recommendation for critical tasks? No
Uniformity on counter: 3:1



12 in. halogen two puck light bar
Average illuminance: 322 lux
Minimum illuminance: 90 lux
Meets recommendation for critical tasks? Yes
Uniformity on counter: 4:1



24 in. high-power LED "warm white" fixture
Average illuminance: 119 lux
Minimum illuminance: 37 lux
Meets recommendation for critical tasks? No
Uniformity on counter: 3:1



24 in. 5 mm LED "warm white" fixture
Average illuminance: 153 lux
Minimum illuminance: 7 lux
Meets recommendation for critical tasks? No
Uniformity on counter: 22:1



Under-cabinet Lighting Fixture Performance and Cost

Estimates are for a 24-in to 28-in wide cabinet and provide an average of 350 lx on the counter.

light source	fixture type and number	power per cabinet (W)	initial purchase cost (\$)	initial installation cost (\$)	annual lamp replacement cost (\$/yr)	annual energy cost (\$/yr)	lamp replacement frequency (years)
Incandescent	halogen pucks (2)	39 W	\$ 22	\$ 42	\$ 2.40	\$ 4.30	2
	xenon pucks (3)	59 W	\$ 30	\$ 56	\$ 1.50	\$ 6.50	7
	xenon linear (1)	102 W	\$ 60	\$ 56	\$ 2.50	\$ 11.20	7
	xenon strip (1)	162 W	\$ 189	\$ 112	\$ 9.80	\$ 17.70	7
Linear fluorescent	T4 (1)	13 W	\$ 16	\$ 56	\$ 0.80	\$ 1.40	7
	T5 (1)	14 W	\$ 29	\$ 56	\$ 0.70	\$ 1.60	7
	T8 (1)	29 W	\$ 47	\$ 56	\$ 0.70	\$ 3.20	7
Compact fluorescent	triple U flat (2)	15 W	\$ 18	\$ 42	\$ 2.80	\$ 1.60	7
LED*	5 mm linear (1)	19 W	\$ 183	\$ 56	\$ 20.00	\$ 2.10	9**
	5 mm pucks (2)	8 W	\$ 79	\$ 42	\$ 8.60	\$ 0.90	9**
	high-power linear (1)	42 W	\$ 147	\$ 56	\$ 3.20	\$ 4.60	>10**

*Because LED lighting is a relatively new technology, performance and cost are changing on a regular basis. Check for updates to this table at www.lrc.rpi.edu/programs/solidstate/assist/recommends.asp.

**Rated life of the LED source only, not given as a fixture. The actual rated life for the fixture may be less.

Recessed lights



- LED fixtures need to dissipate heat differently than incandescent fixtures



Dedicated LED fixture with replaceable LED module



Non-dedicated fixture with LED replacement lamp

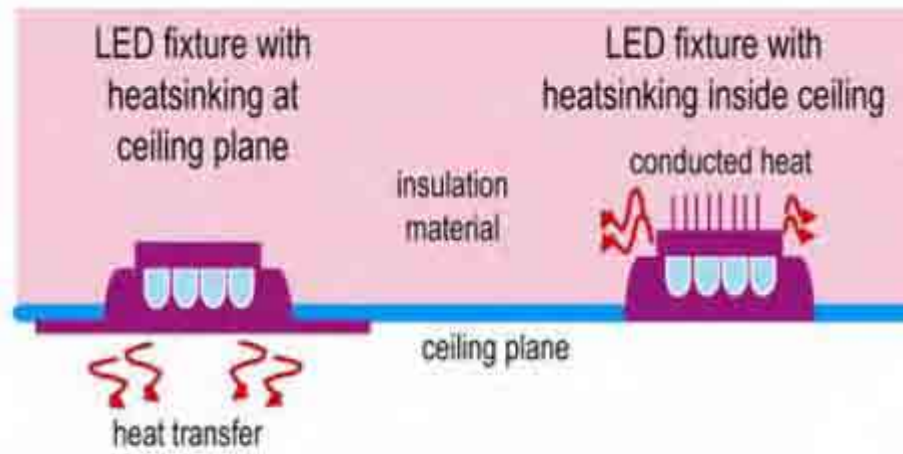
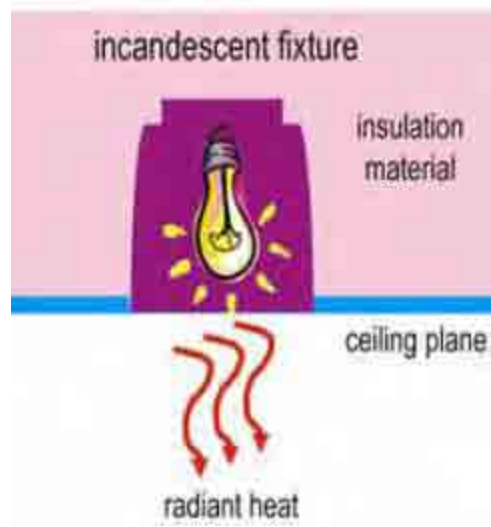

Heat transfer for two LED fixtures with different heat sinking options.



LED Lighting Solutions



Northwest Trade Ally Network
Commercial & Industrial Lighting

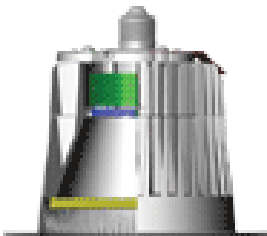

Introducing the LR6 – The New Standard in Downlighting

Industry-Changing Specifics:

- Delivered Lumens = 650
- CRI = 92
- Wallplug Input Power = 11 Watts
- CCT = 2700K or 3500K

General availability
Late Spring 2007



Technology enables the
FIRST and ONLY viable LED product
for general illumination



www.creell.com

Display of recessed products at Lighting Design Lab; LED, CFL, Incandescent



CFL- 13.5 watt



BR30- 65 watt



A19- 60 watt



LED-B- 11.5 watt



CFL-R- 16 watt



LED-A- 15 watt

Foot candles at 6'6" from various light sources

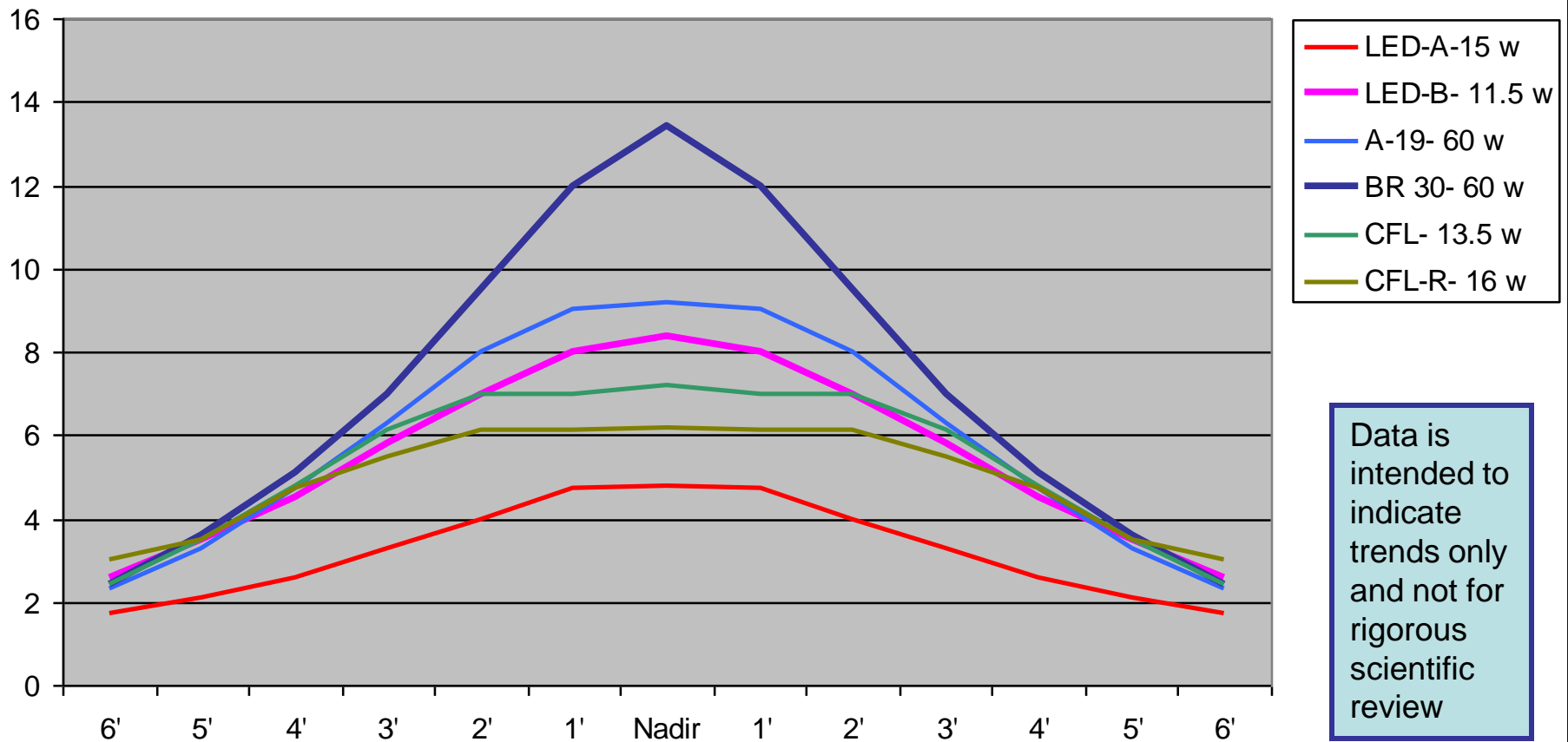

Data is intended to indicate trends only and not for rigorous scientific review



- THE NEXT GENERATION IN CONTEMPORARY DOWNLIGHTING IS HERE.
Aesthetically designed to deliver soft, even illumination throughout a space, the RT5D LED offers the largest lumen package currently available in a downlight.
The energy efficient RT5D LED delivers 50,000 hours of safe and sustainable lighting for worry-free maintenance.



RT5D LED Volumetric Recessed Downlight

PHOTOMETRICS

RT5D LED, 1700 system delivered lumens, test no. LTL16621, tested in accordance to IESNA LM-79-2008

TEST NO: LTL16621
LUMINAIRE CATALOG NO.: RT5D LED
TYPICAL LUMENS PER SYSTEM: 1700 AT 25°C
DISTRIBUTION: DIRECT
FIXTURE TYPE: DOWNLIGHT
SYSTEM TYPE: LED
SYSTEM WATTS: 40

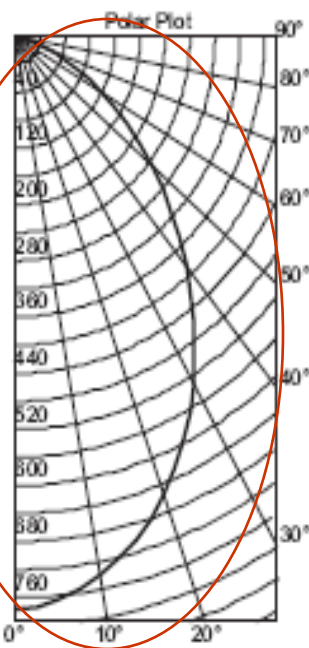

Intensity Distribution		Zonal Lumen Summary		pc pw	Coefficients of Utilization			
Vertical Angle	Horizontal Angle Lumens	Zone	Lumens % Lamp		80% 50%	20% 70%	70% 50%	50% 30%
0		0° - 30°	589 34.6	0	119 119	116 116	111 111	
5	77	0° - 40°	919 54.1	1	106 103	104 101	100 97	
10		0° - 60°	1471 86.5	2	94 88	92 87	89 84	
15	212	0° - 90°	1700 100.0	3	84 76	82 75	79 74	
20		90° - 180°	0 0.0	4	75 67	74 66	71 65	
25	301	0° - 180°	1700 *100.0	5	68 59	67 59	64 58	
30		*Total Efficiency		6	61 53	60 53	59 52	
35	330			7	56 48	55 47	54 47	
40				8	51 43	51 43	49 42	
45	306			9	47 40	47 39	46 39	
50				10	44 36	43 36	42 36	
55	246							
60								
65	159							
70								
75	63							
80								
85	7							
90								

42.5 l/w



LED Lighting Solutions

LIGHTING
for
tomorrow

Northwest Trade Ally Network
Commercial & Industrial Lighting

LR4

4" Recessed Architectural Downlight

- Cree LED Recessed Down Lights Win International Design Competition for Second Straight Year
- Recognized by U.S. Department of Energy as First and Only Down Lights to Exceed Energy Star[®] Requirements

www.creell.com

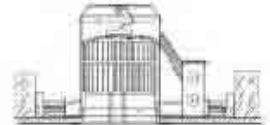

LR4



HA



LR4E-30 and LR4E-15



LR4-30A and LR4-15A

LED Roadway lights

- The Municipality of Anchorage, AK, USA has joined the LED City program, an international community of government and industry parties initiated by LED maker Cree Inc of ~~Durham, NC, USA~~ to evaluate, deploy and promote LED lighting for municipal infrastructure. The city's participation was announced in conjunction with an energy-related initiative calling for the retrofit of all **16,000** municipal roadway lights with high-efficiency LED fixtures.



Baseline – 100 watt high pressure sodium “cobra head” street light



High Pressure Sodium @ 15ft

System Watts: 133

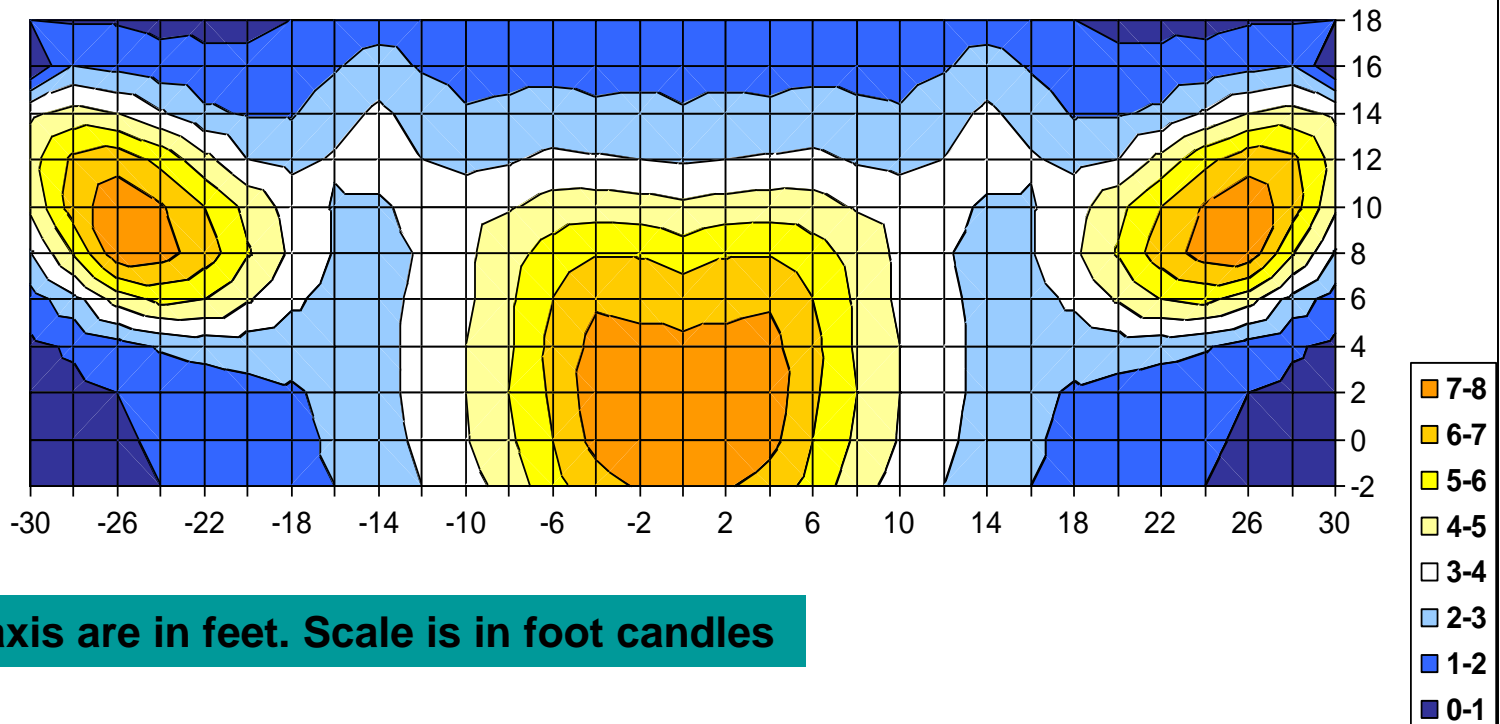

X and Y axis are in feet. Scale is in foot candles

All of the tests

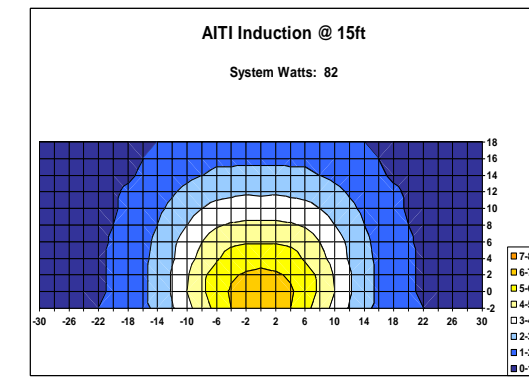
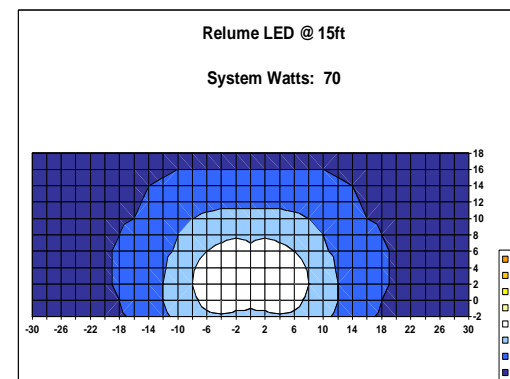
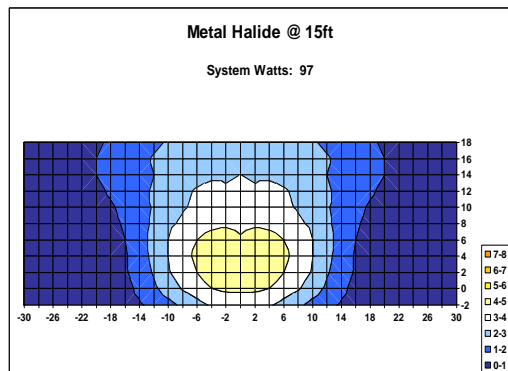
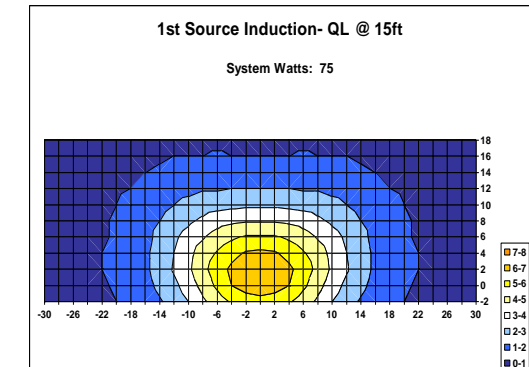
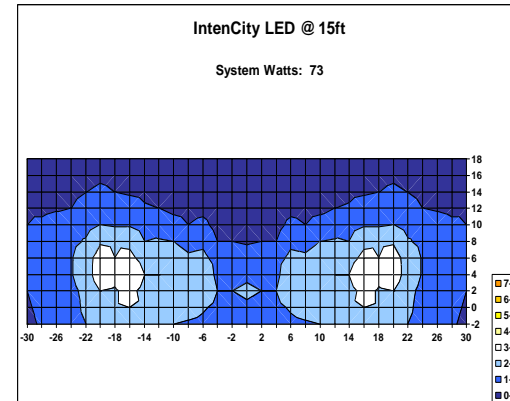
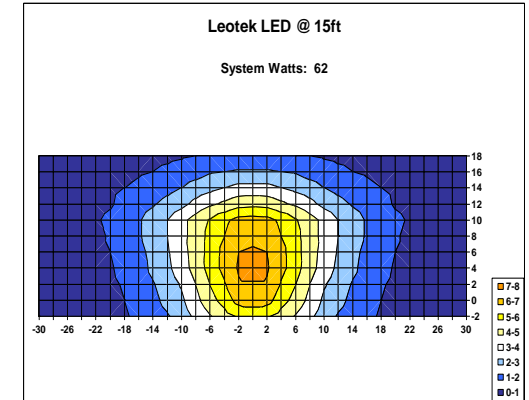
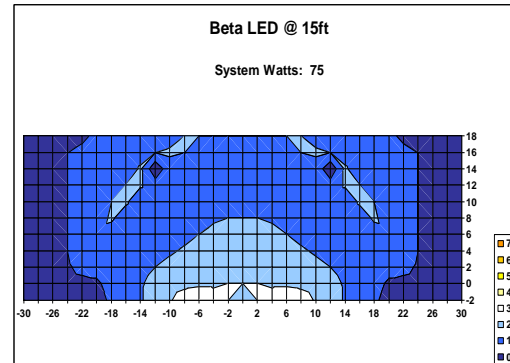
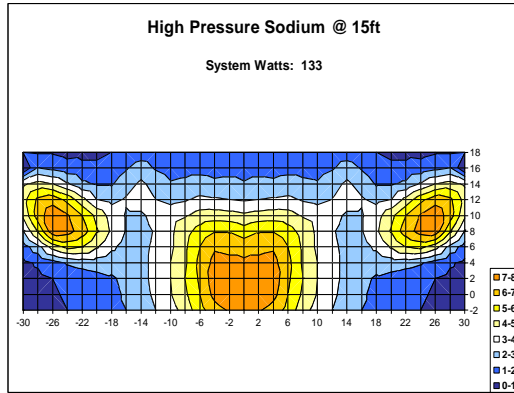



- LEDway- street and tunnel luminaires
- Uniformity, control, and white light improve safety.
- Modular Design
- Die-Cast and Extruded-Aluminum Housing, Wet Listed
- Optional Backlight Shield
- Two-Level Option
- UL, Class I
- IES Full Cutoff Optics

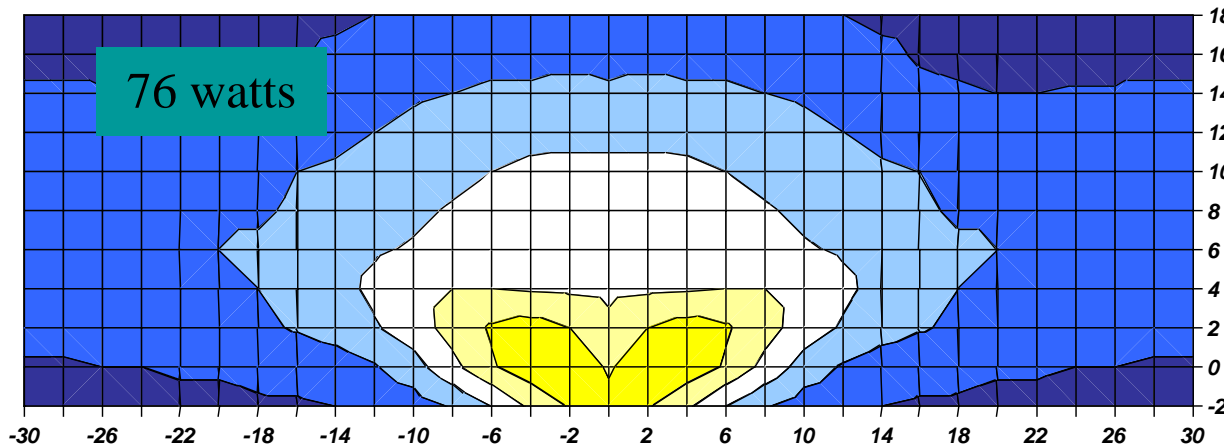

LED- exterior



About 90 watts



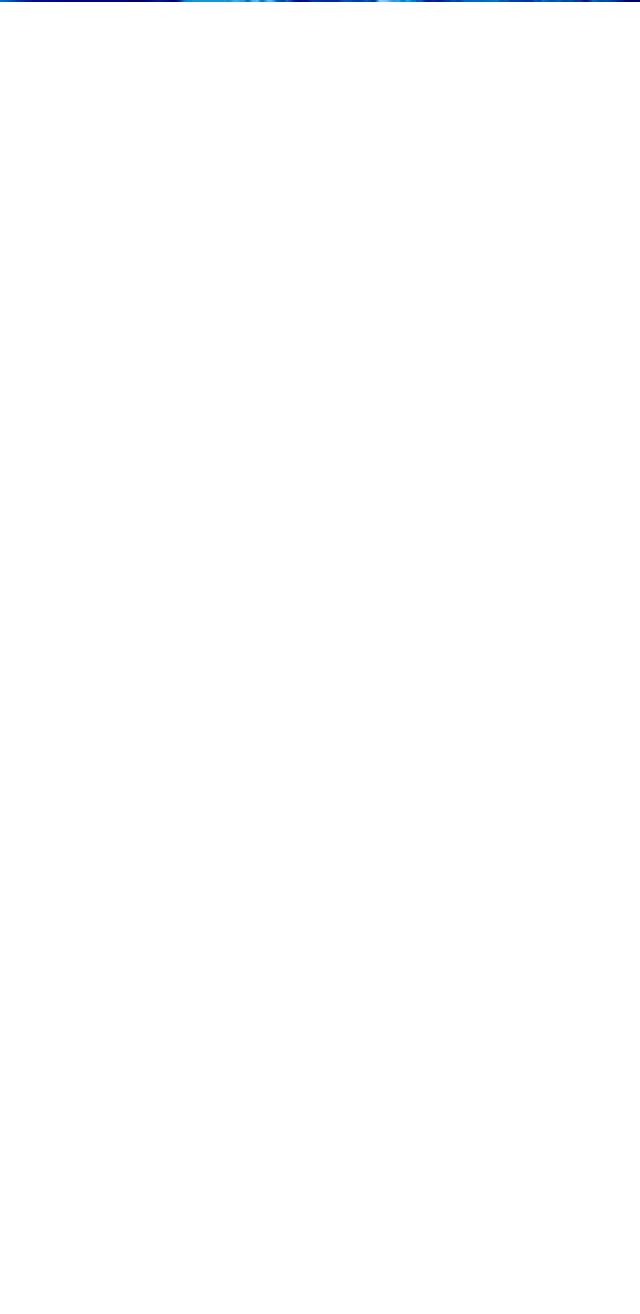

Manufacturers product credibility.

- Are there credible testing methods used for the product you are considering?
- LM-79-08 Approved Method:
Electrical and Photometric
Measurements of Solid-State Lighting
Products
- LM-80-08 Approved Method:
Measuring Lumen Depreciation of
LED Light Sources.



www.ies.org/shop/

Customer says: “I want to use LEDs!”

- Ask what their goal is.
 - Saving energy?
 - Saving money?
 - Better lighting?
 - Being “Green”
 - Using the “Latest”



What is the embodied energy in this product?

OLEDs

- OLEDs (Organic Light-Emitting Diodes) are thin, organic materials sandwiched between two electrodes, which illuminate when an electrical charge is applied. OLEDs are flexible, so they can be incorporated into things like wallpaper, curtains and car interiors. GE has been developing OLEDs since 1999, and in 2003 they demonstrated a 2'x2' OLED light source





BUY PRODUCTS THAT MAKE A DIFFERENCE

U.S. Environmental Protection Agency - U.S. Department of Energy

About ENERGY STAR | News Room | FAQs | **ENERGY STAR**

Search:

- Products
- Home Improvement
- New Homes
- Buildings & Plants
- Partner Resources

Home » Products » Lighting » Light Fixtures » Residential LED Lighting

Residential LED Lighting

ENERGY STAR qualified LED lighting is a natural fit for cutting-edge renovation, new construction projects, or do-it-yourself upgrades. ENERGY STAR qualified residential LED lighting uses at least 75% less energy, lasts 25 times longer than incandescent lighting and provides optimal light color.



Why Choose ENERGY STAR Qualified LED Lighting?

Learn what the ENERGY STAR mark really means and the benefits of quality LED lighting.



Buyers Guide

Learn about the types of LED lighting and what to know before you buy.



Learn About LEDs

Learn how LEDs work and why they are different from other lighting.



LED FAQs

Search for more answers about LEDs.

Find a Store

Special Deals

LED Lighting Resources and Top Partners

Resources

- [Quality Products List](#)
- [Participating Manufacturers](#)
- [Learn About LEDs](#)
- [FAQ](#)

Residential

- [Why Choose ENERGY STAR](#)
- [Buyers Guide](#)

Commercial

- [Why Choose ENERGY STAR](#)
- [Buyers Guide](#)

Products

- Appliances
- Heating & Cooling
- Home Electronics
- Lighting
 - Light Bulbs (CFLs)
 - Light Fixtures
 - Decorative Light Strings
 - Advanced Lighting Package
 - Ceiling Fans
 - Commercial LED Lighting
- Commercial Food Service
- Office Equipment
 - [Outsourcing & Employment](#)
 - [Procurement & Performance](#)

Join ENERGY STAR

Email This Page

Products | Home Improvement | New Homes | Buildings & Plants | Partner Resources | Site Feedback | News Room | Contact Us | Privacy | Site Map | Business and Industry | EPC | Home | Social Media



Northwest Trade Ally Network
Commercial & Industrial Lighting

http://www.energystar.gov/index.cfm?c=ssl.pr_residential



LIGHTING *for* tomorrow

Beautiful, energy
efficient lighting for your home.

ALA | CEE | DOE | PNNL

2008 Competition

[Home](#)

[Winners](#)

[Press](#)

[Publications](#)

[Entry Requirements](#)

[2009 Competition](#)

Past Competitions

[2007](#)

[2006](#)

[2005](#)

[2004](#)

2008 Sponsors

The organizers and lead sponsors of **Lighting for Tomorrow** are:



American Lighting Association (ALA)



Consortium for Energy Efficiency (CEE)



U.S. Department of Energy (DOE) –
represented by Pacific Northwest National Laboratory



Pacific Northwest National Laboratory

The following companies and organizations have generously contributed additional resources to support the competition:



[EChydro](#)



[Tionneville Power Administration](#)

Additional Information

Important Dates

- **January 2009** –
2009 Competition Launched
- **March 2009** –
Final-to-submit forms due
- **April 2009** –
All entries due
- **September 2009** –
2009 Competition Winners Announced

[Sponsors](#)

[Contacts](#)



Solid-State Lighting



- SSL Home
- What is Solid-State?
- Completed Research
- ASSIST Program
- Learning About SSL
- LRC Publications
- Sponsors
- Events Calendar
- Site Map



NYSERDA

ASSIST program

This site was funded by the New York State Energy Research and Development Authority and the ASSIST program.

Solid-State Lighting News at the LRC

An Energy-Efficient, Ultra-thin LED Luminaire

Downlights, accent lights, and wall-wash luminaires using halogen or incandescent lamps are found in 60 percent of all commercial office buildings and a much higher percentage of retail and residential applications. The Lighting Research Center, with sponsorship from the California Energy Commission's PIER program, explored a new "ultra-thin" luminaire concept for these applications. [Read more](#)

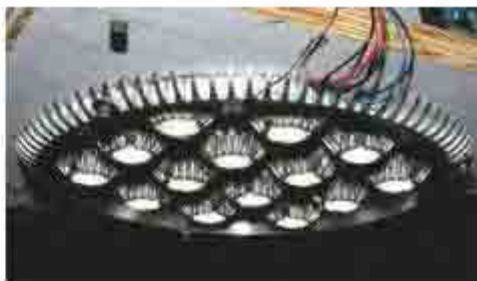

More SSL news:

- [ASSIST Testing Recommendations for LED Light Engine for Decorative Lighting](#)
- [LED Aviation Signal Brightness](#)
- [LED Luminaire Performance: Changing Traditions](#)

<http://www.lrc.rpi.edu/programs/solidstate/index.asp>

The Solid-State Lighting Program at the LRC

Solid-state lighting has the potential to revolutionize the lighting industry. Light-emitting diodes (LEDs)—commonly used in signs, signals and displays—are rapidly evolving to provide light sources for general illumination. This technology holds promise for lower energy consumption and reduced maintenance.

The Lighting Research Center's Solid-State Lighting Program team conducts necessary research and educational programs to enhance this technology, overcome barriers, and help it to gain acceptance for general illumination purposes. The program's multidisciplinary staff focuses its efforts in the areas of:

- **Lighting systems and components research**— studying component interactions and their effect on system performance
- **Human factors research**— studying how people perceive and react to lighting conditions





Building Technologies Program

Solid-State Lighting

DOE SSL Strategy

R&D Project Portfolio

Market-Based Programs

Quality Advocates

ENERGY STAR

ENERGY STAR

Standards Development

Technical Information Network

Technology Demonstrations

Design Competitions

Using LEDs for General Illumination

LED Basics

LED Application Cases

LED Measurement Series

Funding Opportunities

Publications

Related Articles

Home

Solid-State Lighting Portfolio Strategy

DOE has made a long-term commitment to advance the development and market introduction of energy-efficient white-light sources for general illumination. Solid-state lighting (SSL) differs fundamentally from today's lighting technologies, and its unique attributes drive the need for a coordinated approach that guides technology advances from laboratory to marketplace. DOE has developed a comprehensive national strategy that encompasses Basic Energy Science, Core Technology Research, Product Development, Commercialization Support, Standards Development, and an SSL Partnership.

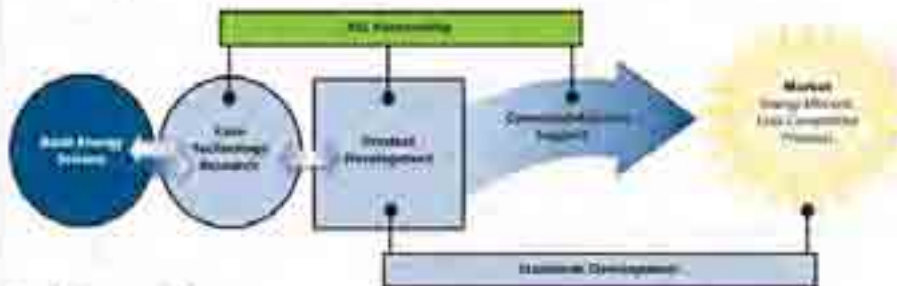

Basic Energy Science

The Basic Energy Sciences Program within DOE's Office of Science conducts basic research to advance our fundamental understanding of materials behavior, with the goal of impacting future directions in applied research and technology development. Project results often have multiple applications, including SSL.

Core Technology Research

Through a series of ongoing, interactive workshops, DOE and its SSL partners have refined an extensive R&D agenda to ensure that DOE funds the appropriate research topics that will improve efficiency and speed SSL technologies to market. Core Technology Research - conducted primarily by academia, national laboratories, and research institutions - involves applied research efforts to seek more comprehensive knowledge about a subject. These projects fill technology gaps, provide enabling knowledge or data, and represent a significant advance in our knowledge base. For a more detailed definition of Core Technology Research, see [Definition of DOE SSL R&D Pathways](#).

Product Development

Conducted primarily by industry, Product Development is the systematic use of knowledge gained from basic or applied research to develop or improve commercially viable materials, devices, or systems. Laboratory testing is conducted on prototypes, and feedback is used to improve prototype design. In addition to technical activities,

<http://www.netl.doe.gov/ssl/strategy.html>



[News & Events](#)

[Competition Overview](#)

[Competition Requirements](#)

[Program Partners](#)

[About](#)

[Join](#)

[Current Partners](#)

[Energy & Environmental Impact](#)

Transforming the Lighting Landscape

The L Prize competition will substantially accelerate America's shift from inefficient, dated lighting products to innovative, high-performance products. Just as Thomas Edison transformed illumination over a century ago, the L Prize will drive innovation and market adoption.

The L Prize is the first government-sponsored technology competition designed to spur lighting manufacturers to develop high-quality, high-efficiency solid-state lighting products to replace the common light bulb.

[Competition Requirements](#)  (PDF 6 MB)

News & Events

L Prize Competition Adds Nine New Partners

*Potential to reach **100 million** consumers!*



The U.S. Department of Energy (DOE) announced it has added nine new partners who agree to work cooperatively to promote the winners of the Bright Tomorrow Lighting Prize or L Prize competition. The following energy efficiency organizations and utilities each signed a Memorandum of

Understanding with DOE: DTE Energy, Sierra Pacific Power (now doing business with Nevada Power as NV Energy), Eugene Water and Electric Board, Seattle City Light, Energy Trust of Oregon, Midwest Energy Efficiency Alliance (covering nine states), NSTAR Electric, Commonwealth Edison Company, and Cape Light Compact. Sixteen partners from coast to coast are now on board to bring utility programs and other incentives for winning L Prize products.

[Learn more](#)

Related Links

[Department of Energy Solid-State Lighting website](#) 

Learn more about solid-state lighting at the [U.S. Department of Energy Solid-State Lighting](#)  website



**Category
Award**



- LIFI Street & Area 40-01
This innovative solid-state 250 watt lamp has 120 LPW, 30,000hr life, 95 CRI, rugged, dimmable, instant on with no restrike time, while being programmable and addressable.
- LIFI™ light sources use a solid-state device to generate RF (radio frequency) energy to power a plasma light source

www.luxim.com/



<http://www.youtube.com/watch?v=ITGsM9pplUs&feature=related>

What are the utilities doing?

